

** THIS IS YOUR SPARE PARTS LIST. SAVE FOR FUTURE REFERENCE, ORDER BY PART NUMBER. CURRENT PRICES WILL BE QUOTED.**

SPARE PARTS LIST

ITEM	DESCRIPTION	ASSY/PART #
1	SIDE FRAME (LH)	630-019M
2	SIDE FRAME (RH)	630-020M
3	FRAME SPACER	630-005M
4	CYLINDER ASSEMBLY	630-102A
5	TRUNION	630-003M
6	CAM PIN	630-012M
7	CAM FOLLOWER	630-011M
8	TRUNION BOLT	630-006M
9	CLEVIS PIN	150-012M
10	RETAINING RING	1039F
11	CLAMP SCREW	1110F
12	STRUT WELDMENT	622-115A
13	OLEO RAW WELDMENT (LH)(RH)	622-113 LH/622-114A RH
14	TORQUE LINK ASSEMBLY	620-112A
15	SPRING 8" LONG	150-019P
16	CLEVIS PIN	620-012M
17	AXLE BAG ASSEMBLY	620-142A
18	#4-40 x 1/4" PPHMS	1047F
19	TRUNION PIN **	630-333M
20	PIN RETAINING RING **	1132F

OPTIONAL GEAR DOOR BRACKET INSTALLATION INSTRUCTIONS

FOR USE ON 1/2" DIAMETER STRUTS

- SLIP THE GEAR DOOR BRACKET DOWN OVER THE UPPER STRUT TUBE. DO NOT LOCK IN PLACE AT THIS TIME.
- CUT A SECTION OF 5/64 ID BRASS OR ALUMINUM TUBE APPROX. 3/4" LONG.
- SLIP THE PIECE OF TUBING YOU JUST CUT ONTO A LENGTH OF 5/64 DIAMETER MUSIC WIRE. BEND THE WIRE INTO A SHAPE SIMILAR TO WHAT IS SHOWN HERE. YOU WILL HAVE TO VARY THE ACTUAL SHAPE AND LENGTH TO FIT YOUR INSTALLATION.
- TEMPORARILY LOCK THE DOOR BRACKET IN POSITION ON THE STRUT. OPEN THE SPLIT END OF THE BENT WIRE AND INSERT INTO THE HOLES IN THE SIDES OF THE DOOR BRACKET.
- TAPE THE BENT WIRE WITH TUBE TO THE INSIDE OF THE GEAR DOOR AND CHECK THE OPERATION OF THE GEAR AND DOOR. ADJUST THE POSITIONS OF THE BRACKET AND WIRE AS REQUIRED TO PROVIDE SMOOTH OPERATION AND A TIGHT FITTING DOOR. GLUE ONLY THE TUBE TO THE DOOR AFTER FINAL POSITIONING.

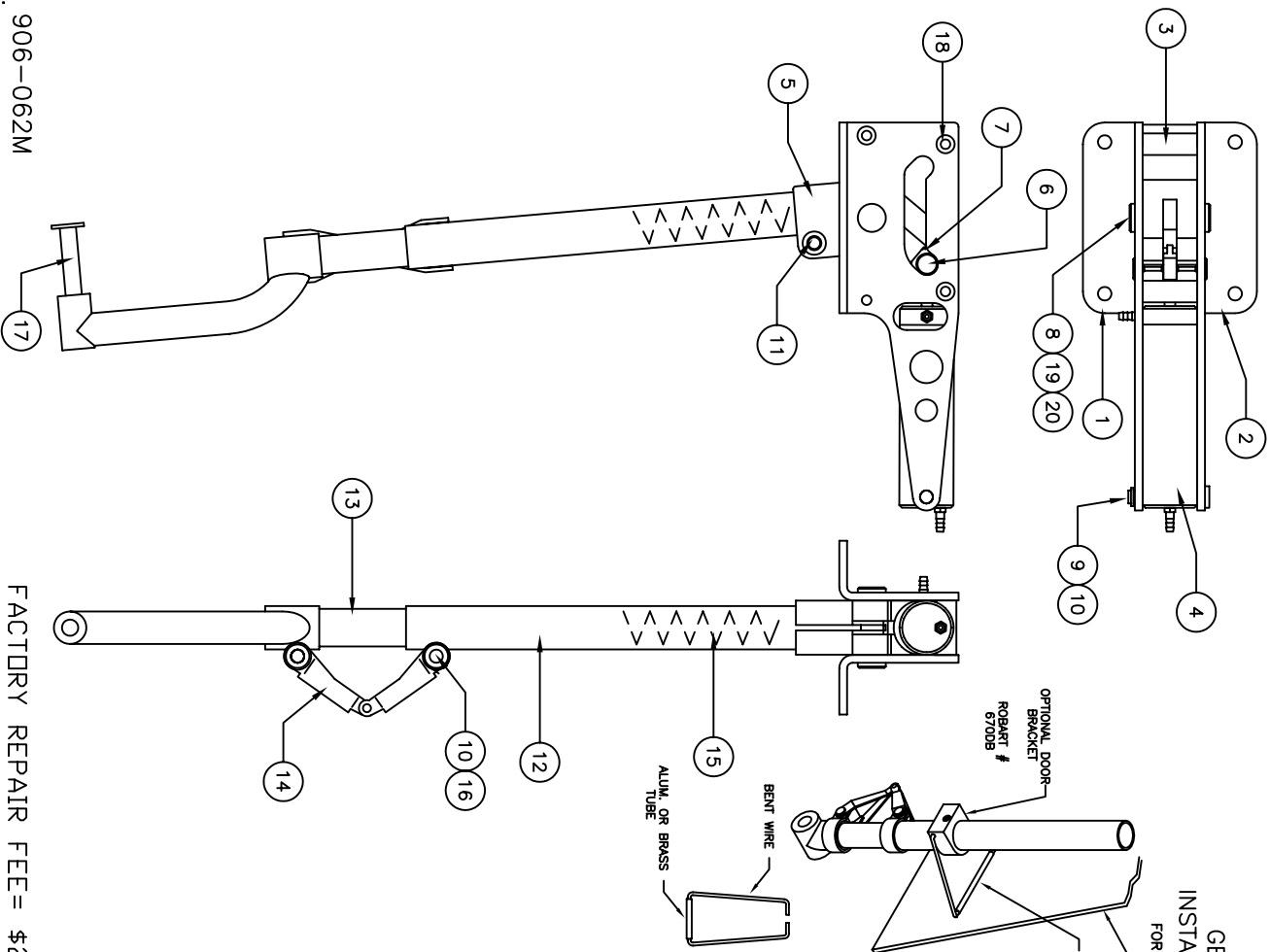

- NEW STYLE USES PIN WITH RETAINING RINGS



- OLD STYLE USES BOLTS

** USED FOR NEW STYLE
NOTE WHICH STYLE WHEN ORDERING

906-062M

FACTORY REPAIR FEE= \$25.00 PLUS PARTS

CHK'D BY		MFG. INC.
DRAWN BY	J. REHAK	625 N. 12TH ST. ST. CHARLES, IL (630)584-7616
DATE	6-12-02	www.robart.com
MODEL No.	633	TITLE
		85° PNEUMATIC RETRACT 4" OFFSET STRUT