

PARTS LIST. SAVE FOR FUTURE REFERENCE, ORDER BY PART NUMBER. CURRENT PRICES WILL BE QUOTED.\*\*

AXLE BAG ASSEMBLY = WB25-142A

## SPARE PARTS LIST

QTY	ITEM	DESCRIPTION	ASS'Y/PART #
1	1	SIDE FRAME (LH)	630-015M
1	2	SIDE FRAME (RH)	630-016M
3	3	FRAME SPACER	630-005M
1	4	CYLINDER ASSEMBLY	630-102A
1	5	TRUNION	630-023M
1	6	CAM PIN	630-012M
2	7	CAM FOLLOWER	630-011M
2	8	TRUNION BOLT	630-006M
1	9	CLEVIS PIN	150-012M
1	10	RETAINING RING	1039F
1	11	CLAMP SCREW	1110F
1	12	STEERING SPRING	630-021M
1	13	#6-32 x 1/4 BHCS	1020F
6	14	#4-40 x 1/4' PPHMS	1047F
1	15	STRUT TUBE ASS'Y	WB25-202A
1	16	OLED RAM ASS'Y LH	652-003A
1	17	TORQUE LINK ASS'Y	650-003A
1	18	SPRING	650-038P
2	19	CLEVIS PIN	650-014M
2	20	SNAP RING	1062F
1	21	STEERING ARM ASSEMBLY	WB25-204A
1	22	STEERING BUSHING	630-025M
1	23	AXLE SHAFT	650-010M
1	24	SET SCREW #8-32 x 3/16"	1198F
1	25	TRUNION PIN **	630-333M
2	26	PIN RETAINING RING **	1132F
	27		

\*\* USED FOR NEW STYLE  
NOTE WHICH STYLE WHEN ORDERING

 - OLD STYLE USES BOLTS

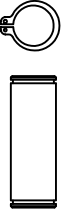
 - NEW STYLE USES PIN WITH RETAINING RINGS

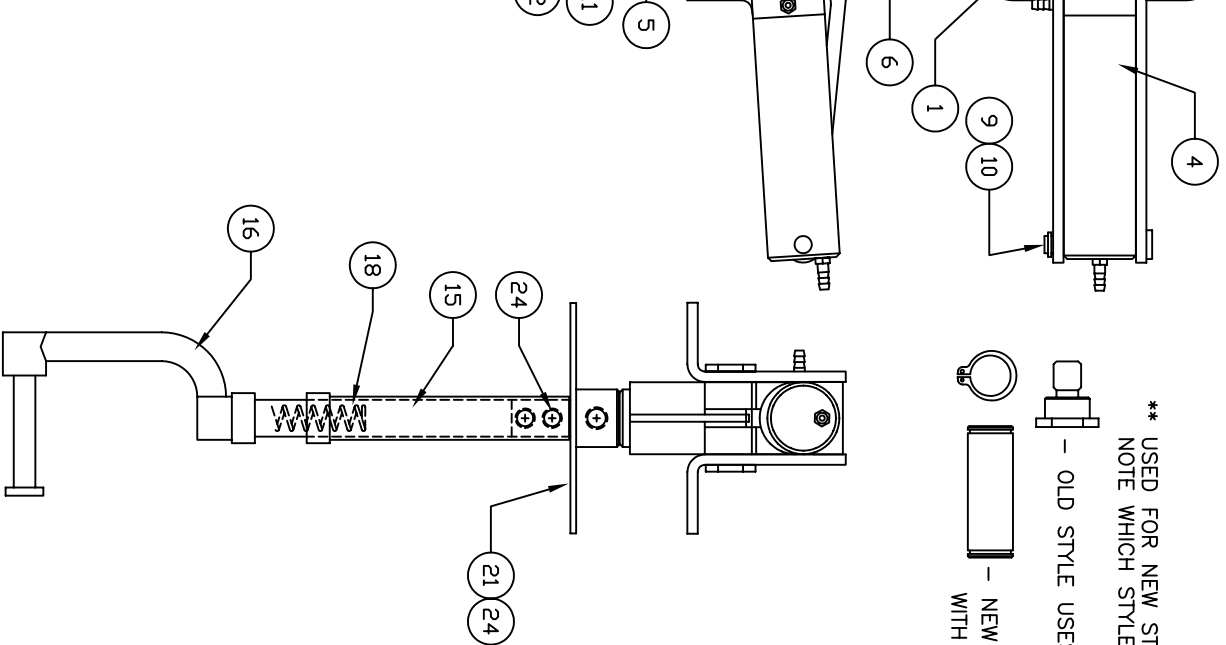

FACTORY REPAIR FEE= \$25.00 PLUS PARTS

CHK'D BY		 MFG. INC. 625 N. 12TH ST. ST. CHARLES, IL (630)584-7616	
DRAWN BY	J. REHAK		
DATE	8/02/02	TITLE	WING B-25 STEERABLE NOSE GEAR
MODEL No.	WB-25		